

Walker Sales & Distribution  
Manufactured Housing Vinyl Railing Installation Instructions

Vinyl Post Sleeve

Sleeving a 4ö x 4ö Vertical Post

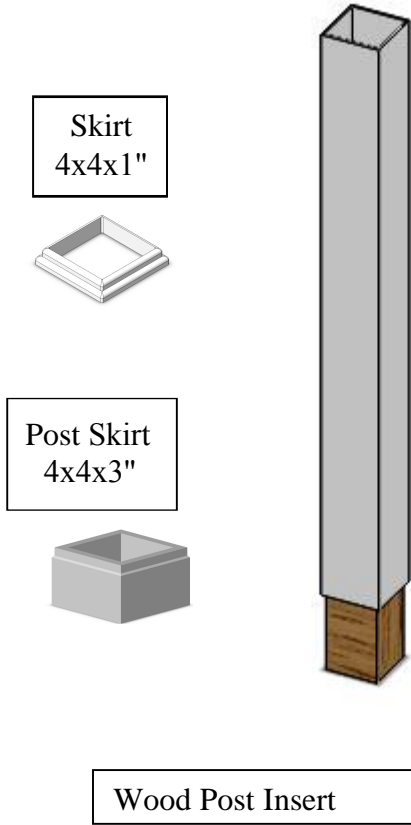

- All vertical sleeves must use a 4x4 wooden insert for support.
- A 4öx4ö1ö decorative post skirt or a 4öx4öx3ö post skirt can be used to finish the top and bottom of the post where it fastens to the header and deck.
  - Slide the vertical sleeve over the wood insert
  - Attach the wood insert to the ceiling and porch floor.
  - Slide the vinyl sleeve up and place one #8 x 1 ½ö screw through the vinyl and into the wood, one-half inch down from the ceiling.
- Slide the post skirt to the top and fasten to ceiling with two #8x1 ½ö white decorative aluminum screws or equivalent.
- The bottom post skirt rests on the floor.
- method to trim vertical sleeves for Post skirt (4"x4"x3").
  - When using a 3" skirt on the bottom with a 1" post skirt on top, cut the vinyl 4öx4ö vinyl sleeve 2 5/8ö less than the porch to ceiling height, which allows enough space for your header and deck fastener.
  - Slide vinyl sleeve over wood insert. Slide 1" post skirt and 3" post skirt for base trim over vinyl sleeve. Once the wood insert is fastened in place, slide the 4ö x 4ö vinyl sleeve to ceiling and place a #8 x 1½ö non-corrosive screw through the vinyl into the wood, one-half inch down from the ceiling.
  - Slide post skirt to top and fasten to ceiling with two #8 x 1 ½ö white decorative aluminum screws or equivalent.
  - The bottom post sleeve assembly rests on the porch floor.

Routed Top and Bottom Rails

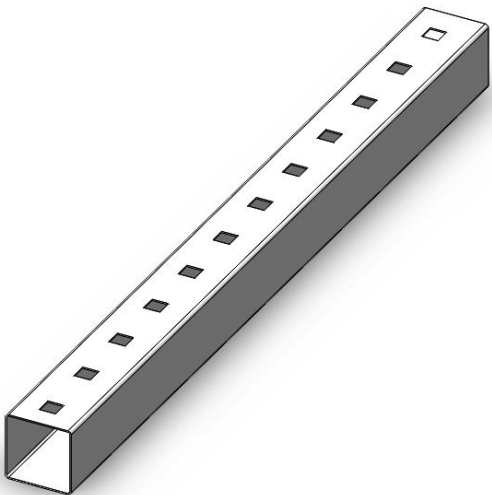

Cutting Rail Lengths

- Measure the distance between posts or post and wall and cut rails 1/16ö less than opening, ensuring the distance between the picket and post/wall is equal on both sides.
- The top and bottom rails should have the same spacing. Scribe rails and cut.

Note: If the end comes within a picket hole, both ends of the rail will need to be shortened. The vinyl collar covers the top and bottom rail ends approximately 1 ¼ö.

- Cut the rail reinforcement the same length as the vinyl rail length.

Galvanized insert

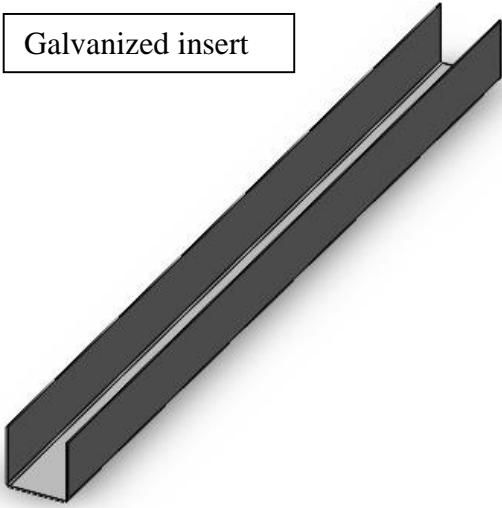

- It is recommended that when cutting galvanized rail reinforcement Cold Gal be sprayed on the cut end to protect metal.
- Slide rail reinforcement into the top and bottom rail as per recommendation below.
- Rail reinforcement recommendations:
  - 16 ga steel reinforcement is required in the top rail for lengths up to 6 feet. Bottom rail reinforcement is optional at 6 feet or less.
  - For opening over 6 ft and up to 8 ft, 14 ga reinforcement required top and bottom. Rails should not exceed 8 ft.
- The open side of the rail reinforcement must be toward the picket openings in the rail. The short leg length of reinforcement should be installed toward the outside of the deck.

### Rail and Vinyl Bracket Installation

- Set the bottom rail with the vinyl brackets on both ends, approx. 3 1/2" above the deck surface against the wall/post in the location desired. Finished rail height should be 36" above deck surface. 42" where required by local code.
- Set the bracket in place.
- Use four stainless steel screws to secure in place. Stainless steel #12 x 1 1/2" screws are supplied (#3 phillips head driver needed).
- Place the precut pickets in the bottom rails and follow the above steps to secure top rail.

Note: Top rail should bottom out on the pickets.

- After rail sections are installed, one #12 x 1 1/2" stainless steel screw must be installed through the side of each top rail bracket as shown. The screw must go through the bracket, rail and steel support. A 5/32" drill bit is needed to predrill the hole.

